

RENAULT TRIBER



life on demand

Renault Triber is everything you need from a seven-seater car. Modular, efficient and practical, it fits perfectly in your everyday life.



With its dual tone design, advanced connectivity and enhanced safety pack, Renault Triber is your companion for the city and beyond.

modular from
5 to 7 seats

modular with
100+ seat
combinations

up to 625L
boot space

enhanced
driving
assistance
systems

20.32 cm
touchscreen
mediaNAV with
Apple CarPlay &
Android Auto

India's safest 7-
seater*

interactive menu

01. design

02. modularity

03. driving comfort

**04. advanced driving assistance
systems**

05. customization

looks the part

Renault Triber stands tall with fresh, muscular look, comfortable, spacious interior and a range of customizable dual tone options. Every detail, from the 15" styled flex wheels* to the LED turn indicators, is smartly designed to make Renault Triber the go-to choice.



*for RXZ

switch it up

With space for up to seven people, the removable third row of seats and 625l of trunk space*, Triber's ultra-modular interior gives you comfort, flexibility and a lot of storage possibilities.



With modularity to go from 5 to 7 seats and over 100 possible seating combinations, Renault Triber gives you all the space you need for your lifestyle.



mode 7-seater



mode 5-seater



mode 4-seater



mode 2-seater

[experience virtually →](#)

03. driving comfort

feeling good

Triber's sophisticated, ergonomic and spacious cabin means you and your family can focus on enjoying the ride. From the 20.32 cm touchscreen mediaNAV with Apple CarPlay™ & Android Auto™, to the air conditioning and hands-free access, it's got it all.



Dual tone dashboard & multimedia screen with smartphone replication

Renault Triber has an internal storage of 23.34 liters, including refrigerated console which keeps food and beverages cool during short or long trips, for your utmost comfort.

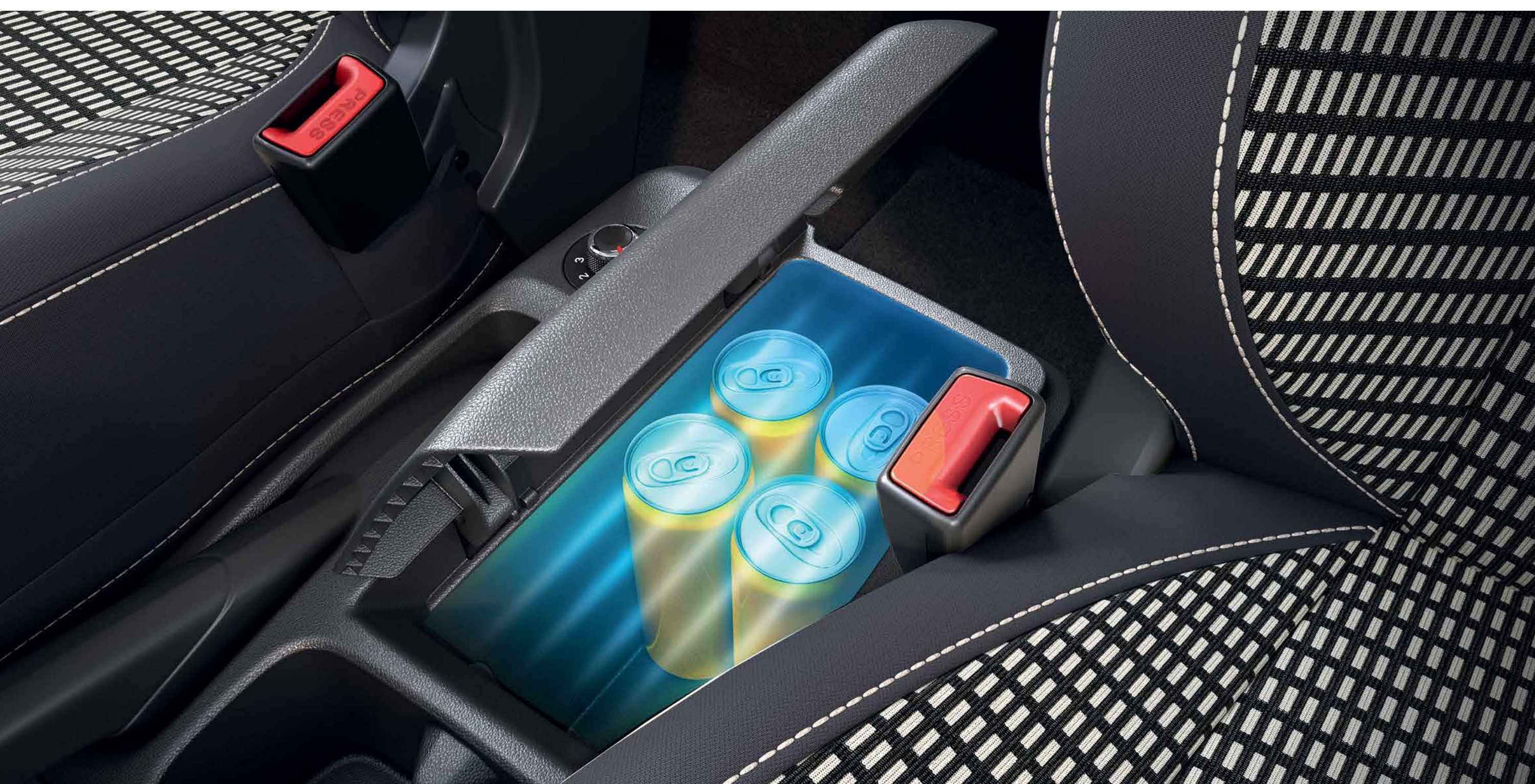

refrigerated central storage

*for RXT and RXZ
Android Auto™ is a Google Inc. brand.
Apple CarPlay™ is a trademark of Apple Inc.

[explore more →](#)

[menu ↑](#)

04. advanced driving assistance systems



9 advanced driving assistance systems

As part of the human first program and in compliance with BS6 step 2* norms, Renault Triber is equipped with nine innovative advanced driving assistance systems.

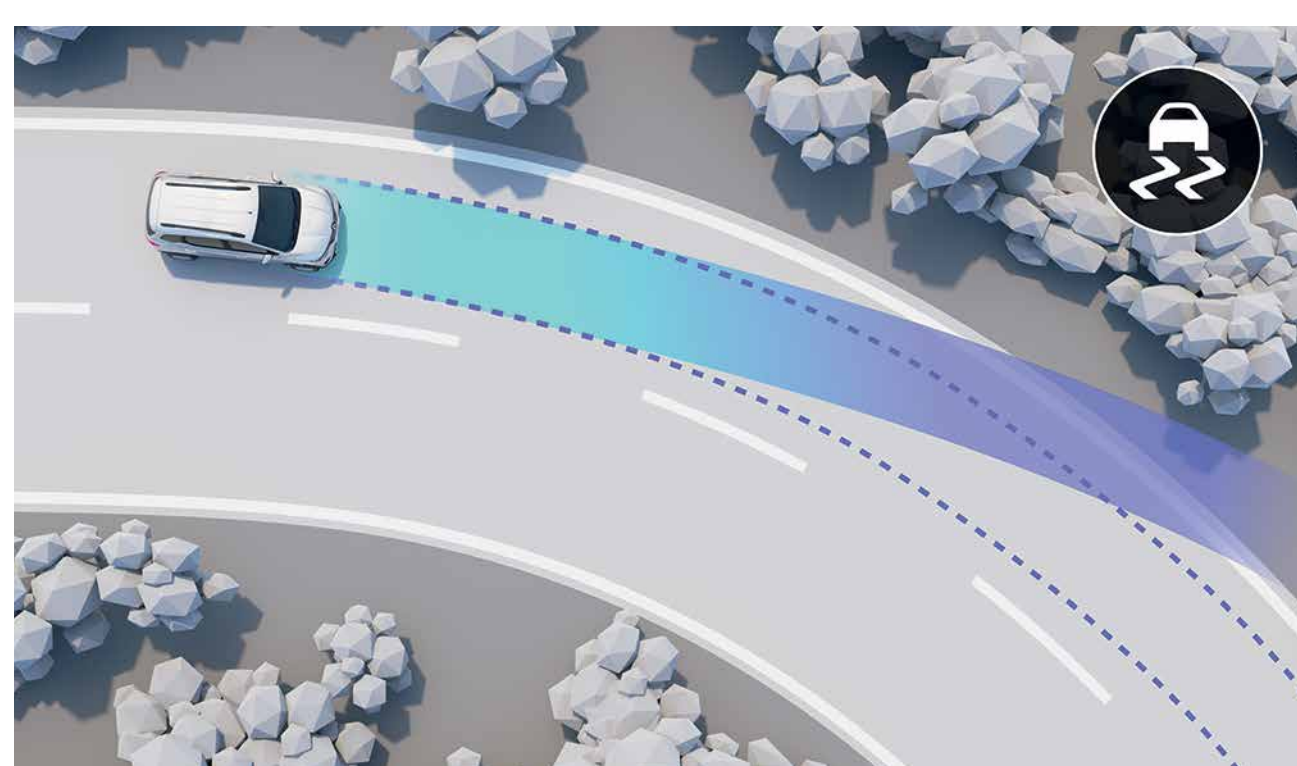

new electronic stability program
Automatically corrects your car's trajectory so you avoid dangerous skids.

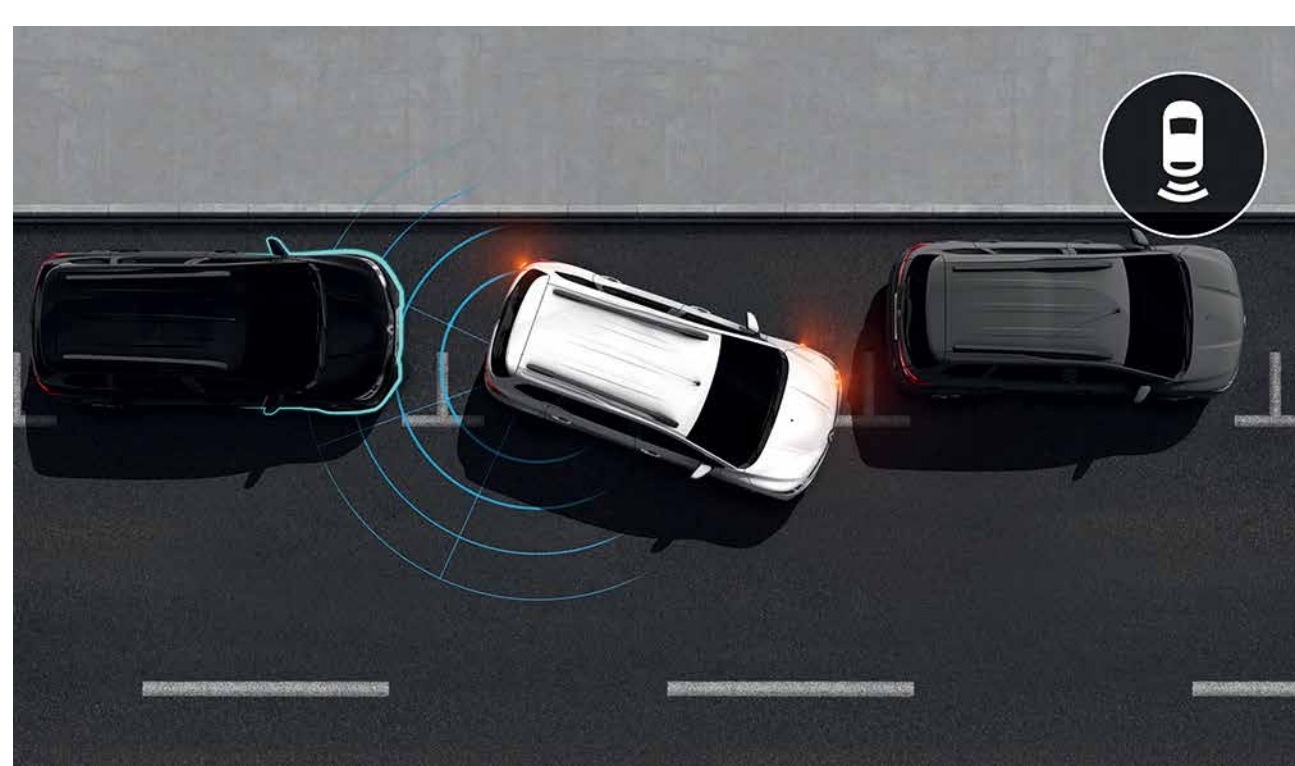

rear parking sensor
Ultrasonic sensors in the rear bumper measure the distance between the vehicle and an obstacle.



new traction control system
Limits wheel slip during starting, acceleration and braking.



airbag
Four airbags offer* increased protection.



new hill start assist
Maintains brake pressure for two seconds, preventing rollback when you move away on a steep slope.



new tyre pressure monitoring system
The tyre pressure monitoring system displays the tyre pressure status in real time with a pictogram on the dashboard. Always know the condition of your tires.

driving assistance

- ABS + EBD
- new electronic stability program
- front airbags
- new traction control system

security assistance

- brake assist
- new tyre pressure monitoring system
- load limiter + pretensioner (driver only)

parking assistance

- rear parking sensors

*4 airbag available in RXZ only

[explore more →](#)

[menu ↑](#)

05. customization

color palette



moonlight silver



metal mustard



ice cool white



electric blue



cedar brown

dual tone color palette



moonlight silver with mystery black roof



metal mustard with mystery black roof



ice cool white with mystery black roof



electric blue with mystery black roof



cedar brown with mystery black roof

* dual tone colours only available in RXZ
* moonlight silver & ice cool white only available in RXE
* photos not contractually binding

[explore more →](#)

[menu ↑](#)

05. customization

interior trims



RXE

- wheel centre cap
- LED instrument cluster - white colour
- 12V socket - 1st row only
- speed alert warning



RXL=RXE+

- full plastic wheel cover
- ORVM – manual internal adjust
- speed sensing door lock



RXT=RXL+

- LED turn indicator on ORVMs
- japda fabric upholstery
- ORVM - electrical adjust



RXZ=RXT+

- LED DRLs
- stylish akaza fabric upholstery
- 12V socket - 3rd row
- 2 side airbags (front seats)

05. customization

upholstery



meson black fabric



japda fabric



stylish akaza fabric

wheel rims



wheel centre cap



full plastic wheel cover



styled flex wheel cover

explore more →

05. customization

accessories



illuminated logo

Add character to your Tribesman by fitting and flaunting a lit-up Renault logo on its back.



roof carrier

A bolder presence and lots of extra space – that's what the solid roof rack carries along.



alloy wheels

The subtle and remarkable silver alloys add a style element to the car.



chrome garnish on front grille

First impressions matter so make it a lot more stunning with chrome accents on the grille.

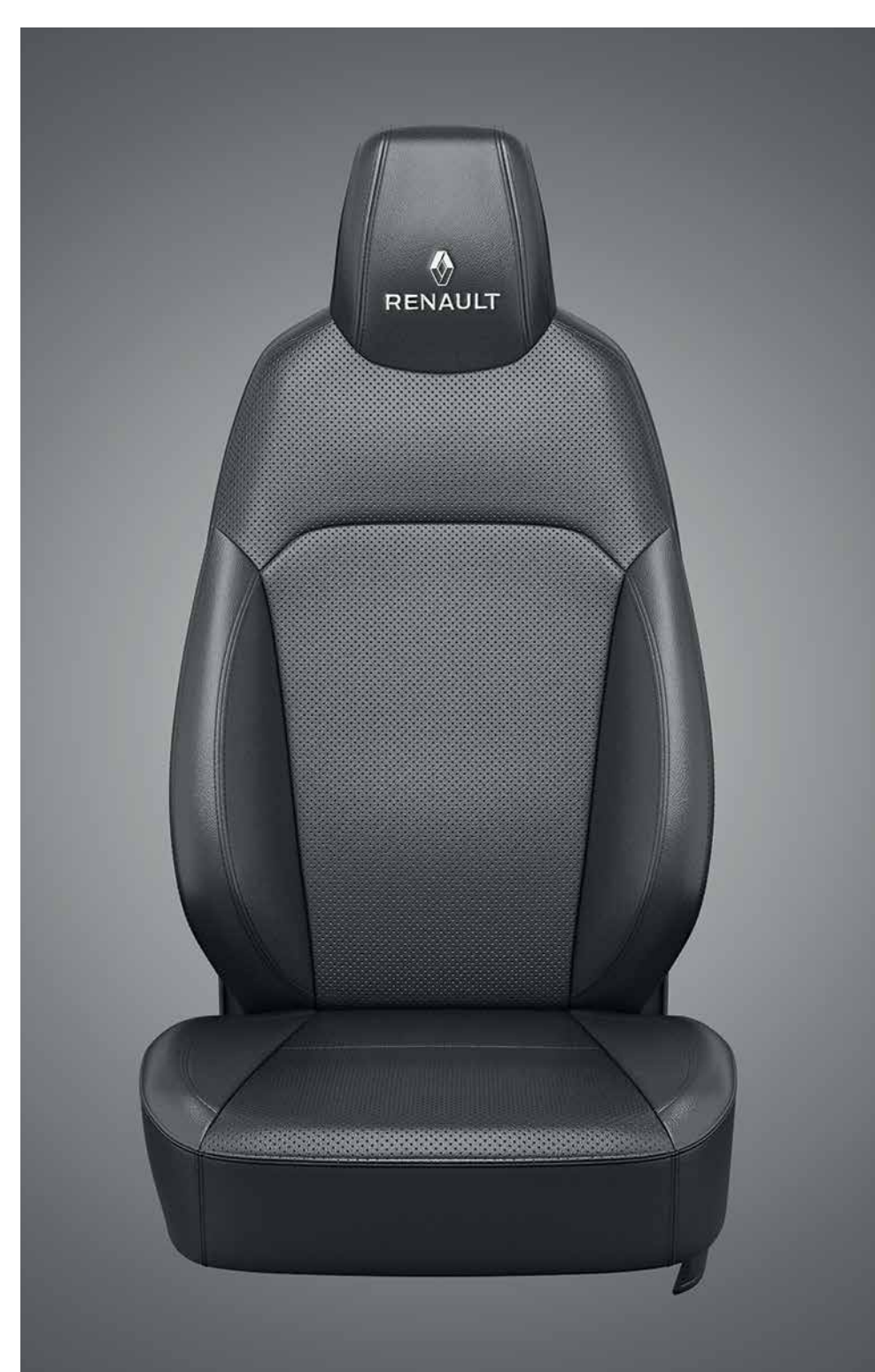
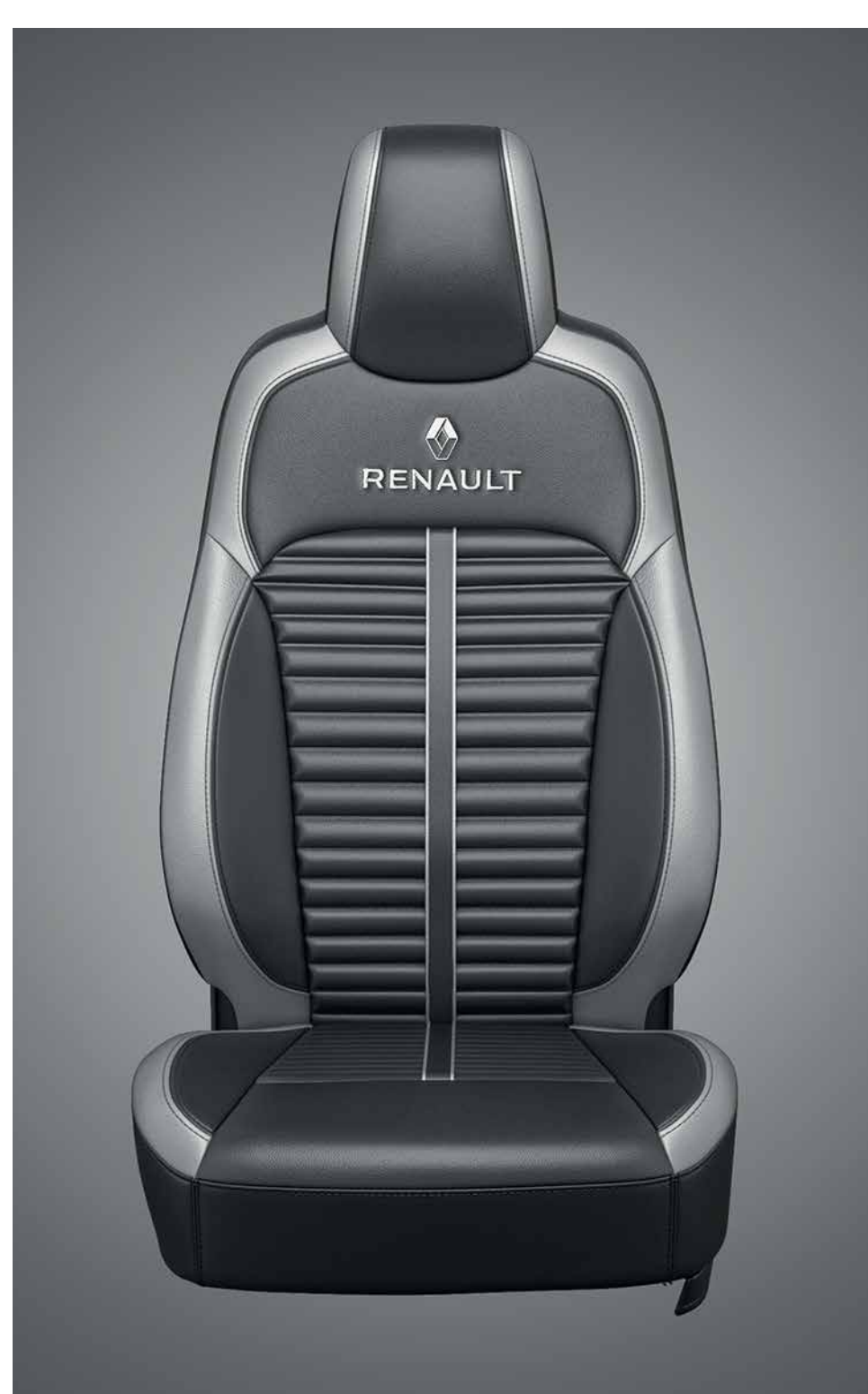

seat covers

Enhance the cabin look with a range of seat covers.

[explore more →](#)

[menu ↑](#)

dimensions and volumes

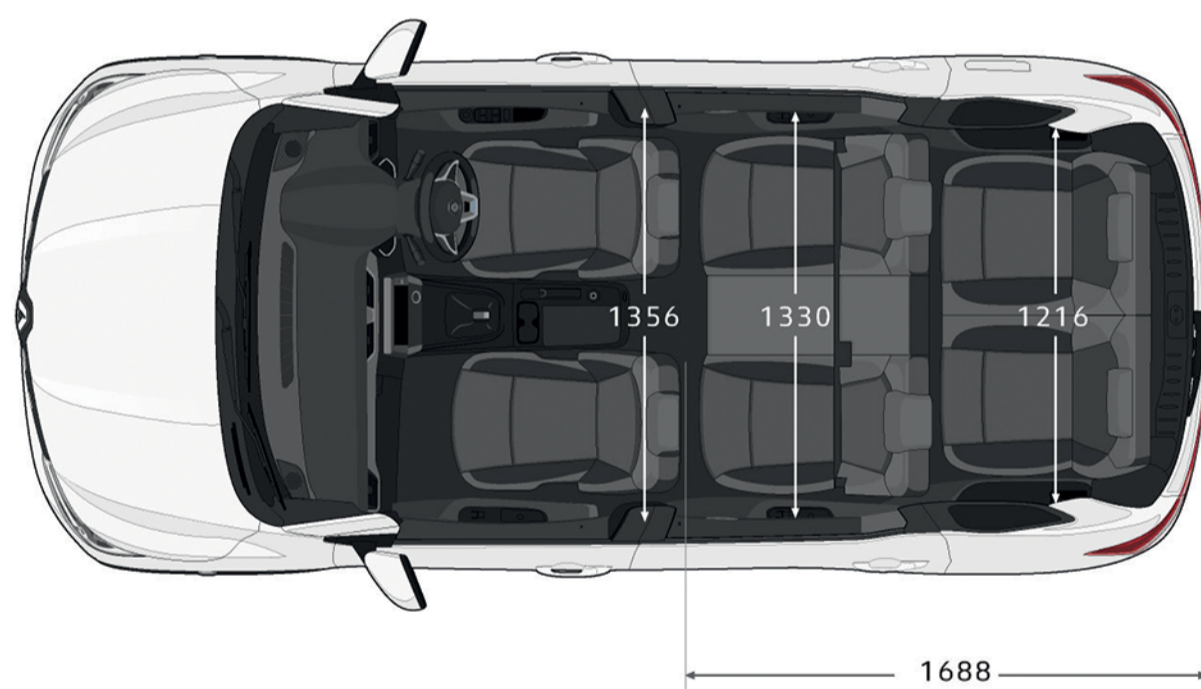
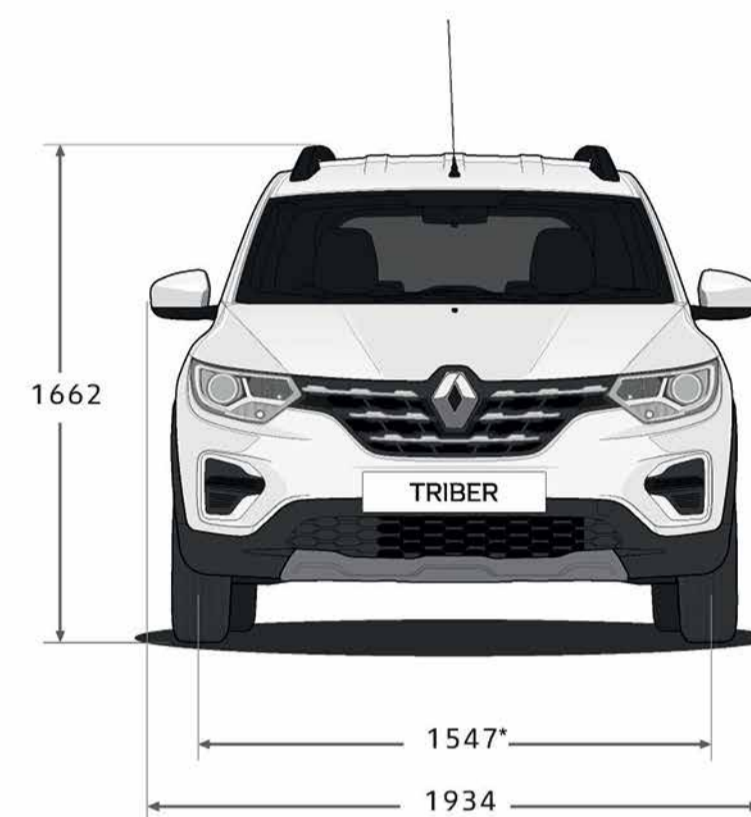
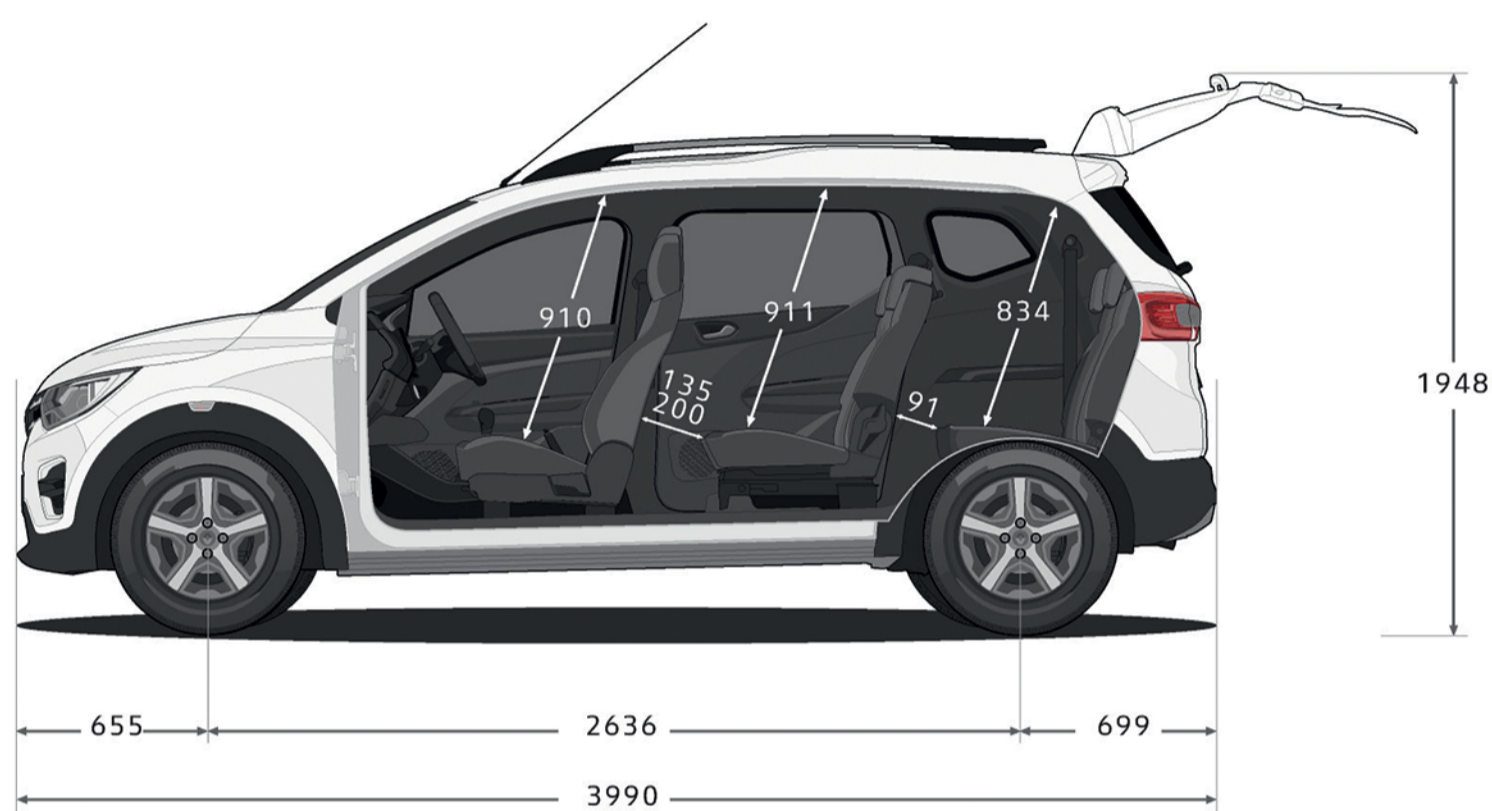

*except RXZ

[explore more →](#)

engines

	RXE	RXL	RXT	RXZ
engine & transmission	energy MT	energy MT	energy MT & EASY-R	energy MT & EASY-R
displacement			999	
number of cylinders			3	
maximum power output (ps @ rpm)			72 @ 6,250	
maximum torque (N.m @ rpm)			96 @ 3,500	
transmission type	5-speed MT	5-speed MT	5-speed MT & Easy-R AMT	5-speed MT & Easy-R AMT
fuel system			multi point fuel injection	
steering				
type			electric power steering	
suspension				
front			MacPherson strut with lower triangle & coil spring	
rear			torsion beam axle	
brake				
front			disc	
rear			drum	
wheels and tyres				
tyre (mm)	165 / 80	165 / 80	165 / 80	185/65
wheel rim (cm)	35.56	35.56	35.56	38.1
dimensions & capacities				
overall length (mm)			3,990	
overall width without mirrors (mm)			1,739	
overall height without roof rails (mm)			1,643	
front track (mm)	1,547	1,547	1,547	1,527
rear track (mm)	1,545	1,545	1,545	1,525
fuel tank capacity (litres)			40	
ground clearance (mm)			182	
boot space (l)				
mode 5 seater			625	
mode 7 seater			84	

equipment and options

	RXE	RXL	RXT	RXZ
exterior design				
projector headlamps	▪	▪	▪	▪
wheel arch cladding	▪	▪	▪	▪
body colour bumper	▪	▪	▪	▪
wheel centre cap	▪	▪	▪	-
black ORVMs	▪	▪	▪	-
black door handle	▪	▪	-	-
full plastic wheel cover	-	▪	▪	-
roof rails with load carrying capacity (50kg)	-	▪	▪	▪
triple edge chrome front grille	-	-	▪	▪
body coloured door handle	-	-	▪	-
mystery black ORVMs	-	-	▪	▪
SUV skid plate front & rear	-	-	▪	▪
LED turn indicator on ORVMs	-	-	▪	▪
chrome door handles new	-	-	-	▪
styled flex wheels	-	-	-	▪
LED DRLs	-	-	-	▪
dual tone exterior with mystery black roof + ORVMs (optional)	-	-	-	▪
interior design				
dual tone dashboard	▪	▪	▪	-
black inner door handles	▪	▪	▪	-
air vents (front side) with chrome	▪	▪	▪	▪
LED instrument cluster – white colour	▪	▪	▪	▪
meson black fabric upholstery	▪	▪	-	-
HVAC knobs with chrome ring	-	-	▪	▪
japda fabric upholstery	-	-	▪	-
stylish akaza fabric upholstery new	-	-	-	▪
dual tone dashboard with silver accents	-	-	-	▪
chrome finished parking brake buttons, knobs on front air vents and push button surround	-	-	-	▪
piano black finish around mediaNAV evolution	-	-	-	▪
silver finish – inner door handles and steering wheel insert	-	-	-	▪
comfort				
electric power steering	▪	▪	▪	▪
on-board computer	▪	▪	▪	▪
front power windows	▪	▪	▪	▪
manual air conditioning with heater	▪	▪	▪	▪
2 nd row seats – side recline fold and tumble function	▪	▪	▪	▪
easyfix seats: fold and tumble function	▪	▪	▪	▪
60:40 split 2 nd row seat	▪	▪	▪	▪
electrical tail gate release on centre console	▪	▪	▪	▪
open storage on centre console	▪	-	-	-
12V socket – 1 st row only	▪	▪	▪	▪
dual tone horn	▪	▪	▪	▪
tilt adjustable steering	-	▪	▪	▪
rear assist grips on 2 nd & 3 rd row	-	▪	▪	▪
storage in centre console	-	▪	▪	▪
remote central locking	-	▪	▪	▪
ORVMs – manual internal adjust	-	▪	-	-
R&GO audio system with Bluetooth® & USB connection	-	▪	-	-
rear power windows	-	▪	▪	▪
2 front speakers	-	▪	▪	▪
ORVMs – electrical adjust	-	-	▪	▪
rear power windows	-	-	▪	▪
front seat back pocket – passenger side	-	-	▪	▪
mediaNAV evolution with 20.32 cm touchscreen	-	-	▪	▪
2 rear speakers	-	-	▪	▪
twin row AC with 2 nd & 3 rd row vents & independent control	-	-	▪	▪
steering mounted audio & phone controls	-	-	▪	▪
day & night adjustable IRVMs	-	-	▪	▪
rear room lighting	-	-	▪	▪
upper glove box	-	-	▪	▪
cooler centre console	-	-	▪	▪
vanity mirror – passenger side	-	-	▪	▪
12V socket – 2 nd row	-	-	▪	▪
eco scoring new	-	-	▪	▪
2 front tweeters	-	-	-	▪
smart access card (with tail gate release button)	-	-	-	▪
cooled lower glove box	-	-	-	▪
seat height adjust	-	-	-	▪
push button start/stop	-	-	-	▪

equipment and options

comfort (following)				
front seat back pocket – driver side	-	-	-	■
rear wiper, washer & defogger	-	-	-	■
auto up down – driver window	-	-	-	■
rear view camera	-	-	-	■
12V socket - 3rd row	-	-	-	■
safety				
front airbag – driver and passenger	■	■	■	■
ABS + EBD with brake assist	■	■	■	■
electronic stability program new (ESP)	■	■	■	■
tyre pressure monitoring system new (TPMS)	■	■	■	■
traction control system new (TCS)	■	■	■	■
hill start assist new (HSA)	■	■	■	■
load limiter + pretensioner (driver only)	■	■	■	■
speed alert warning	■	■	■	■
seat belt reminder – driver + passenger	■	■	■	■
rear parking sensors	■	■	■	■
pedestrian protection	■	■	■	■
speed sensing door lock	-	■	■	■
impact sensing unlock	-	■	■	■
2 side airbags (front seats)	-	-	-	■
■ = standard. - = not available.				

the human first program is a comprehensive safety programme developed by Renault in collaboration with researchers, experts and fire-fighters.

because road safety is the business of all road users - be they pedestrians, cyclists or motorists - the human first program by Renault undertakes to:

- 1. prevent accidents by developing safety equipment and advanced driving and safety assistance systems**
up to 36 advanced driving assistance systems / more than 60 safety systems, up to 7 airbags, child seats (Isofix), Renault's Fixe4sure solution / more than 2,000 safety-related patents filed since 1970
- 2. reduce the number of accidents and their severity by investing massively in R&D**
safety score / safety coach / connected services / big data / artificial intelligence and cybersecurity systems

find out more about the human first program

Renault care service

We are always by your side to make your driving experience easy and save you time maintaining your Renault. We'll give you online estimates and appointments, service packages, maintenance contracts, insurance, assistance, the My Renault program and more simple, easy solutions perfectly tailored to your needs.

[find out more about Renault care service](#)



accessories/features shown may not be part of the standard fitment. the registration plate is licensed with Renault Group Paris. Renault India Pvt Ltd reserves the right to sale of Renault Triber in India. every precaution has been taken to ensure that this publication is accurate and up to date on the date it is published. this document has been created on the basis of pilot lots and prototypes. as part of its ongoing product improvement policy, Renault India Pvt. Ltd. reserves the right to modify the specifications and vehicles described and shown at any time. such modifications are communicated to Renault dealers as quickly as possible. depending on the country of sale, certain versions may differ and certain equipments may be unavailable (as standard, optional or accessory). the colours that appear on the website may differ slightly from the actual paint or upholstery colours. RXE version available in ice cool white and moonlight silver only. Triber has scored 4-star safety rating for adult occupant safety and 3-star child occupant safety in crash test conducted by Global NCAP. the same has been published by NCAP on their website. the evaluation of the tests by Global NCAP has resulted in Triber being the safest in the 7-seater mass segment in India. please contact your nearest dealer for the latest information. all rights are reserved. the reproduction in any format and by any means of all or part of this publication without prior written authorisation from Renault is prohibited. segment definition based on Renault internal classification. *BS6 step 2 compliant (as per Gazette of India REGD. NO. D. L.-33004/99 norms). our customer service team is available on our toll-free number from Monday to Sunday, between 07:00 am to 11:00 pm.

www.renault.co.in
Call: 1800 315 4444

Renault recommends  **Castrol**

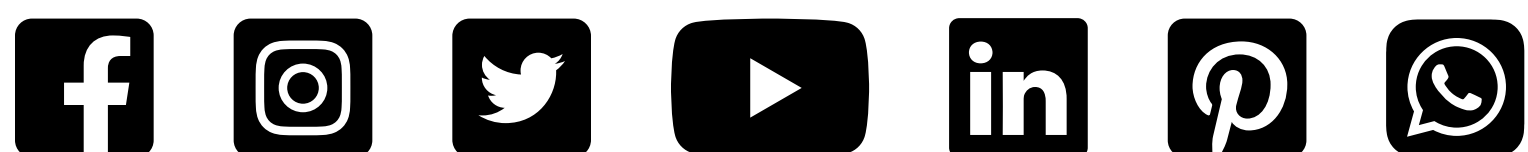

locate a dealer →